

Magnetic Liquid-Level Gauges for LP Gas Service



Applications

Junior gauges are supplied standard with 0015-00007 Buna-N gasket and four 0040-00414 zinc-plated steel mounting bolts (1/4" – 28x 1/4") for attachment to a gauge adapter with 2.03" [52,5] diameter bolt circle (see installation instructions MS-501/502).

Models 6281 and 6284 Junior gauges used on above ground ASME storage tanks are equipped with R3D® Remote Ready 5909S02733 percentage dials. Model 6281 Junior gauges used on below ground ASME storage tanks are equipped with R3D® Remote Ready 5909S02799 percentage dials. Models 6241 and 6244 Junior gauges used on ASME motor fuel tanks come with the option of direct read, TwinSite®, or Hall Effect dials.

All gauges in the 6240 series and B6240 series incorporate a stronger magnet necessary to drive remote reading TwinSite® senders in motor fuel applications.

All Senior gauges except models 6290 and 6293 come equipped with 0015-00004 Buna-N gaskets and four 0040-00415 zinc plated steel mounting bolts, (5/16" — 24 x 7/8"), for attachment to a gauge adapter with 2.5" [63,5] diameter bolt circle (see Rochester Adapter Machining Standard MS-502). Model 6280 and 6283 Senior gauges used on above ground ASME storage tanks are equipped with direct-reading 5001S00001 percentage dials.

Models 6290 and 6293 Senior gauges with stainless steel heads may be used on above ground horizontal or vertical ASME storage tanks over 3500 [13250 liters] gallon capacity and are equipped with cap bolts, teflon-filled, stainless steel gaskets, stronger magnets and direct-reading 4" diameter percentage dials. Tank drawings must be furnished for all vertical tanks so we can recommend computer generated gauge adapter placement to correspond with an assortment of standard dials and dial sets calibrated for vertical tanks.



Junior Models	Description
6281	For top mounting, includes standard magnet to drive direct-reading dials.
6284	Same as 6281, except for side, end, or angle mounting.
6241	For top mounting, includes stronger magnet to drive TwinSite® senders.
6244	For side, end, or angle mounting, otherwise same as 6241.
B6244	Same as 6244, except with brass head.

Junior Models	Description
6280	For top mounting, includes standard magnet to drive direct-reading dials.
6283	Same as 6280, except for side, end, or angle mounting.
6290	For top mounting, includes stronger magnet to drive large 4" dial.
6293	Same as 6290, except for side, end, or angle mounting.

General Specifications*

Temperature Range

Standard range is -40°F to 176°F, -40°C to 80°C with optional stainless steel mounting bolts which may be required for temperature below -20°F.

Accuracy

Accuracy depends upon gauge sizing. Junior and Senior dials ±5%, 4" dials ±4%, TwinSite® dials ±8%. Hall dial output ±4% of visual reading. Accuracy may be less depending upon tank shape. Accuracy may be less near full and empty. Accuracy may be less if tank is not level. Accuracy may be less due to variation in liquid temperature. This gauge is not to be used for filling. All accuracy estimates are expressed as percentage of full scale.

Humidity

For high humidity below ground or under chassis applications, brass, stainless steel, or painted aluminium heads are recommended.

Shock & Vibration

Suitable for mobile service applications.

Power

0.5 watts maximum dissipation for TwinSite® versions.

Working Pressure

375 psi. [25,8 Bar]

Approvals

Gauges are UL listed for LP Gas service applications.

When ordering, specify:

1. Gauge head size, Junior or Senior or model #.
2. Tank diameter as shown on nameplate
3. Mounting location (top, side, end or angle).
4. If gauge is angle mounted, state angle.
5. If gauge is end mounted, state the shape of the tank head, hemispherical or semi-ellipsoidal.
6. The "H" dimension (the distance in inches from the surface of the tank to the gasket surface on the riser).

To order replacement gauge, simply furnish the information stamped on one of the flat sections on the side of the gauge head as shown in the example.

Note: for installation instructions see MS-501/502.

*Materials and specifications are subject to change without notice.

Pressure ratings subject to change due to temperature and other environmental considerations.

Materials of Construction*

Head

Aluminium die casting standard. Model B6244 has brass head, models 6290 and 6293 have stainless steel head.

Gear Housing

Aluminium dies-casting or acetal.

Centershaft Bearings, Gear, Pinion, Cross Stud & Bearing, & Dial Screws

Stainless steel.

Support, Centershaft & Float Rod

Tempered Aluminium.

Float Bulb

Nitrile rubber or one-piece aluminium.

Counterweight

Steel-plated.

Magnetic

Neo.

Gasket

Buna-N standard. Spiral wound, Teflon-filled, stainless steel on models 6290 and 6293.

Mounting Bolts

Zinc-plated steel. (Stainless steel optional)

Junior Direct Reading Dials & TwinSite® Senders

Ultrasonically sealed polycarbonate.

Senior Dials

Aluminium with acrylic or polycarbonate crystal, sealed with rubber gasket.

4" Dials

Aluminium with glass crystal, sealed with a rubber gasket.

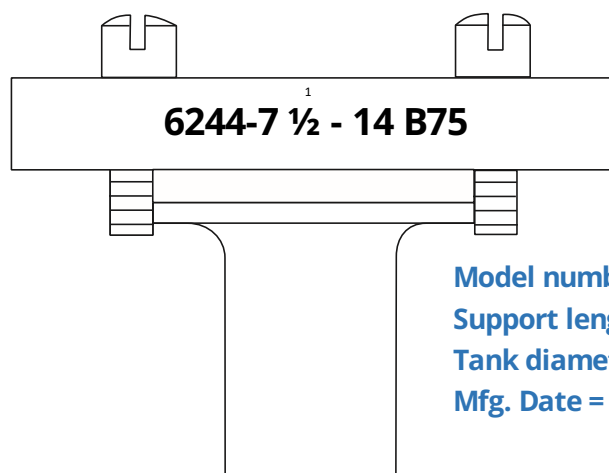

Note: Gauge head may also be stamped with model & unique suffix #.