



Instructions For Installing Rochester 9701 Series Hall Effect Sender Modules

CAUTION: READ COMPLETELY BEFORE ATTEMPTING INSTALLATION

HALL MODULE INSTALLATION PROCEDURE

The following procedure details how to install a Hall Effect transmitter module onto a Rochester Gauges Remote Ready dial.

1. Remove shipping plug from dial. Lift right end and push left end.
2. Remove all dirt and debris from cavity under shipping plug. **NOTE:** Failure to clean cavity properly may result in failure of transmitter module to seat properly and cause reduced accuracy.
3. Slide module into slot on dial from edge of dial. Do not attempt to install module vertically.
4. Apply thumb pressure and push module toward center of dial until it snaps into place. **CAUTION:** Attempts to remove transmitter from dial may result in damage to transmitter, dial, or both.
5. Installation is now complete.
6. To remove module, gently lift square end and push round end.

WARNING: DO NOT LOOSEN OR REMOVE GAUGE MOUNTING BOLTS

REMOTE READY DIAL, TYPICAL

CAUTION: SEE 115-794 "REPLACING DIALS" IF DIAL MUST BE REPLACED.

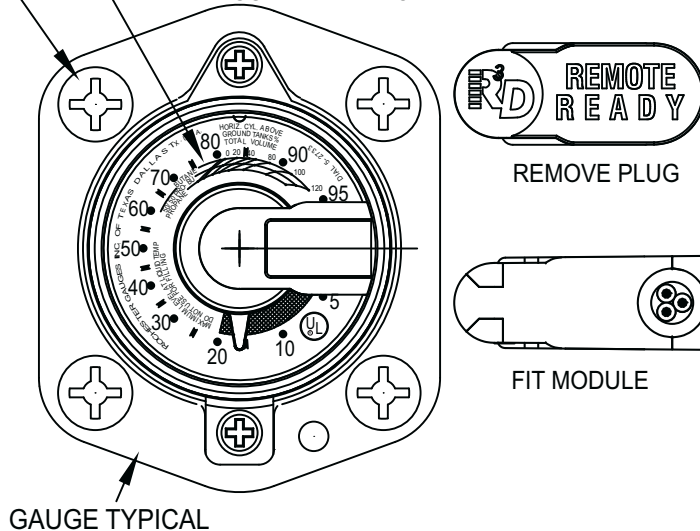

GAUGE TYPICAL

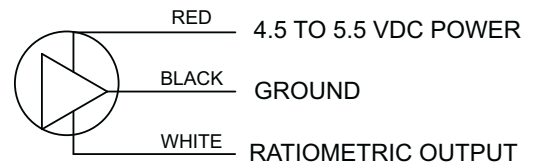

FUNCTIONAL SPECIFICATIONS/VOLTAGE OUTPUT MODULE

CONFORMITY: $\pm 4\%$ @ 5 VDC WHEN ATTACHED TO REMOTE READY DIAL
 OPERATING TEMPERATURE: -40°C TO 80°C
 RESOLUTION INFINITE
 OPERATING VOLTAGE: 4.5 TO 5.5 VDC
 OPERATING CURRENT: 4.5MA TYPICAL
 OUTPUT: RATIOMETRIC, 5-80% OF INPUT VOLTAGE @ 5-80% VOLUME
 OUTPUT CURRENT: $\pm 1\text{MA}$
 SEE DS-1318 FOR APPLICATIONS NOTES.

WARNING: Do not remove gauge mounting bolts. Do not unscrew gauge heads that are screwed into tank. Tank may contain high pressure and flammable gas. A hazard of fire or explosion may exist if gauge mounting bolts or gauge heads are loosened or removed.

For LP-gas and other flammable product service applications, connect only to circuits and power sources Classified and labeled as intrinsically Safe for Class 1, Division 1, Group C and D hazardous locations. The connection of non-intrinsically safe power could cause fire or explosion of flammable vapor which may be present.

U.S. Patents

6,564,632; 6,679,116; 6,584,838

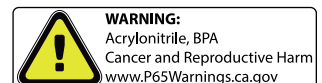

10/30/2019