

Industrial Reed Switch Fuel Level Sender



Application

The Reed Switch line of fuel senders fit tanks 4" [101.6 mm] to 42" [1067 mm]. They are designed for top mounting in aluminum, plastic, steel or stainless steel fuel tanks in all types of industrial equipment. These senders are recommended for both on-road and off-road applications. They include special features and protection from corrosion (internal and external to the fuel tank) which makes them the quality standard for all industries.

General Information & Features

- Standard mounting configuration, 1 1/2" NPTF.
- The head and support are made of stainless steel and is suitable for harsh off-road conditions.
- The sender is suitable for gasoline, ethanol, diesel, bio-diesel, urea and water.
- Industry standard output: 2440-30 ohms.
- The close tolerance held on this series of Reed Switch Fuel level sender will provide the proper signal for any of the popular 2" [50.8 mm] panel mounted receivers or ECM's.



General Specifications*

Mounting - Designed for top mounting only.

Accuracy - Accuracy depends upon proper sender sizing. Resistance values are 30 ohms $\pm 2\%$ at full and 240 ohms $\pm 2\%$ at empty. System accuracy may be less near full and empty. System accuracy may be less if tank is not level. System accuracy may be less depending upon indicator. This sender is not to be used for filling.

Temperature Range - -40°F to 176°F , -40°C to 85°C

Power - 0.5 watts maximum

Leak Test - Passes 16 PSIG [1,1 Bar] test.

Thermal Shock/Hot Dunk Test - 10 cycles in air, $+85^{\circ}\text{C}$ to immersion in Room Temperature Saline.

Dry Bench Cycling - 25,000,000 cycles.

Vibration Test - 6 hours each plane, 9.9 Grms, 24-2,000 Hz.

Salt Spray Test - 96 hours external as mounted.

Drop Test - 1.2m onto concrete from each orientation.

Power Wash Test - 50 cycles, 3,000 psi, 2.7 gal./min.

Lead Pull Test - 20 lbs. harness, 10 lbs. each wire.

Materials of Construction*

Head - Stainless steel

Support - Stainless steel

Float - Nitrile Rubber

Material Compliance - Stainless Steel

Support - RoHS Compliant

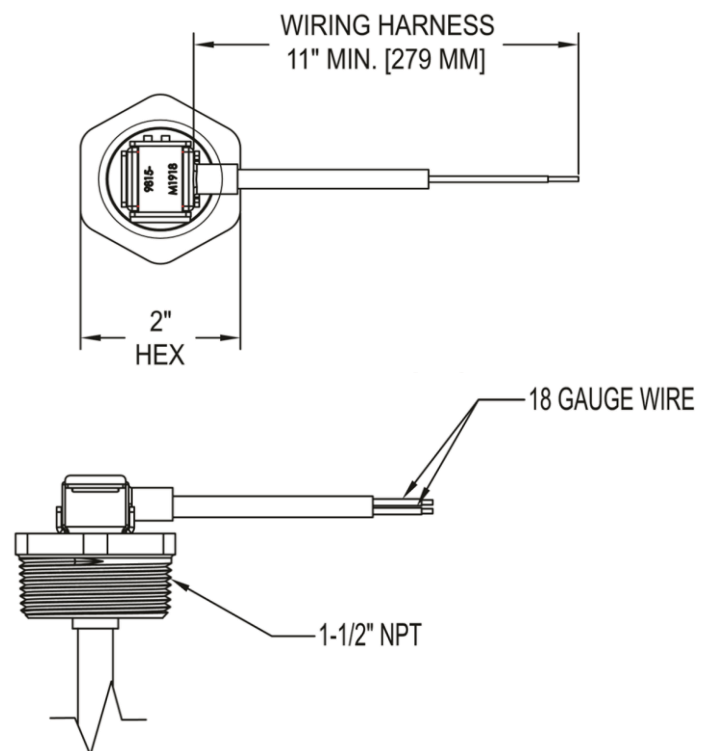

Wiring Harness

18 awg. Wires.

Black & white PVC insulation.

Lack overmolded PVC Jacket.

*Materials and specifications are subject to change without notice.

E. & O.E. ©Rochester Sensors.

Since the suitability of these products depends upon a wide range of factors not in our control, Rochester Sensors expects and understands that you will conduct the testing and evaluation necessary to determine that these products are suitable for your application. Whilst every effort is made to ensure the above details are correct at the time of printing, Rochester Sensors reserves the right to make material changes, and/or technical changes without notification.