

6318 Wireless Dial

Remote-read BLE output sensors for use with existing ASME Tanks and DOT Cylinders



The 6318 Wireless Dial provides a wireless connection between a Rochester Sensors mechanical gauge and the corresponding telemetry system. The self-contained dial reads from the gauge in the tank and broadcasts via a Bluetooth Low Energy (BLE) output to a telemetry system. The 6318 can be retrofitted on existing applications, replacing a conventional dial and R3D module. An integrated LCD provides a percentage full reading in an easy to see display.

The dial is designed to support a 10-year battery life. The 6318 Wireless Dial can be replaced at the end of the service interval. The 6318 Wireless Dial is not user serviceable.

The wireless operation simplifies installation and eliminates any issues with cable connection and subsequent damage during operation. The Wireless transmission allows the telemetry unit to be located farther from the tank to optimize cellular transmission. The 6318 conforms to similar intrinsic safety requirements as the 9700 Series Modules: Class 1 Div 1 for IECEx/ATEX/UKEX/CSA.

The 6318 Wireless Dial is compatible with Rochester Sensors standard 1.5" gauges including medium-duty spiral gauge. It is available in both a snap-on and screw-on versions to replace existing direct read and R3D junior dials. A version of the 6318 Wireless Dial is available for Rochester Sensors Sr Dial gauges with an adapter ring to allow the dial to mount on existing Sr size gauges.

Application

The 6318 Wireless Dial acquires level readings from a tank on 30 second intervals. The sensor broadcasts via BLE every 2.4 seconds. This transmission occurs automatically and does not require pairing with a handheld or similar device. The local LCD is updated every time the sensor takes a new measurement. The 6318 Wireless Dial incorporates a fill detect mode. When a fill is detected, the 6318 sensor will acquire new level readings every second and update the LCD. The 6318 sensor will exit fill mode automatically.

The Rochester Sensors 6318 Wireless Dial supports over-the-air firmware updates via the Bluetooth interface.

General Information and Features

- Polycarbonate housing offers excellent mechanical properties and chemical resistance.
- No exposed sensing elements, all components are located on the PCB inside the housing.
- Ingress Protection: IP6K9K rated.
- Over-the-air firmware update capability
- Snap-on and screw-on versions



E. & O.E. ©Rochester Sensors.







Since the suitability of these products depends upon a wide range of factors not in our control, Rochester Sensors expects and understands that you conduct the testing and evaluation necessary to determine that these products are suitable for your application. While every effort is made to ensure the above details are correct at the time of printing, Rochester Sensors reserves the right to make material changes, and or technical changes without notification.

Key Benefits

- No exposed cables
- Fast installation time
- Easy to read digital display shows tank volume in 1% increments.
- Rugged plastic housing
- Fully sealed, IK09 impact rating
- Field replaceable at end of lifetime

LCD Status Indicators

The 6318 sensor is equipped with a 2-digit 7-segment LCD display. The LCD will show status codes to indicate different conditions. Some status codes are considered errors while some are considered warnings and will affect the level value system wide. Refer to each code for an expected behavior. Refer to Appendix A for all system errors and warnings.

LCD Output	Description
	bL: Battery low. Battery is estimated to be within 1-2 years of expected end of life. The measured level will alternate on the LCD with this code.
	bC: Battery critical. Battery is estimated to be < 1 year of expected end of life. The measured level will alternate on the LCD with this code.
	Er: Device error. Device is not functioning correctly and electronics should be replaced. The Bluetooth level will be set to 0xFFFF.
	Lo: Low or Low-Low Warning. Tank level is below expected operating range.
	Hi: High or High-High Warning. Tank level is above expected operating range.
	Float arm position is out of measureable range and the sensor cannot determine a meaningful number. Bluetooth level indicates 0xFFFF.

E. & O.E. ©Rochester Sensors.

Since the suitability of these products depends upon a wide range of factors not in our control, Rochester Sensors expects and understands that you conduct the testing and evaluation necessary to determine that these products are suitable for your application. While every effort is made to ensure the above details are correct at the time of printing, Rochester Sensors reserves the right to make material changes, and or technical changes without notification.

Product Certification

Rochester Sensors 6318 Jr Ble Dial is certified as intrinsically safe for class 1, Division 1, Groups C & D hazardous locations. Products are marked and approved by ETL, ATEX, UKCA, and CE.

Hazardous Locations Safety Standards	
IEC 60079-0: 2017	Explosive atmospheres – Part 0: Equipment – General requirements *Note: For IECEx Certification
EN 60079-0: 2011 + C1: 2012	Explosive atmospheres – Part 11: Equipment protection by intrinsic safety “i” *Note: For IECEx Certification
EN 60079-0: 2018	Explosive atmospheres – Part 0: Equipment – General requirements *Note: For ATEX Certification
EN 60079-0: 2012	Explosive atmospheres – Part 11: Equipment protection by intrinsic safety “i” *Note: For ATEX Certification
UL 60079-11, 6th Ed., Issued 03/26/2019	Explosive atmospheres – Part 0: Equipment – General requirements *Note: For USA listing Certification
UL 60079-11, 6th Ed., Revised 03/28/2014	Explosive atmospheres – Part 11: Equipment protection by intrinsic safety “i” *Note: For USA listing Certification
CSA C22.2 No. 60079-0: 2011	Explosive atmospheres – Part 0: Equipment – General requirements *Note: For Canada listing Certification
CSA C22.2 No. 6009-11: 2011	Explosive atmospheres – Part 11: Equipment protection by intrinsic safety “i” *Note: For Canada listing Certification

FCC Interference statement (Part 15.19)(a)(3)

This device complies with part 15 of the FCC Rules. Operation is subject to the following two conditions: (1) This device may not cause harmful interference, and (2) this device must accept any interference received, including interference that may cause undesired operation.

FCC Interference Statement — PART 15.105 (B)

Note:

This equipment has been tested and found to comply with the limits for a Class B digital device, pursuant to part 15 of the FCC Rules. These limits are designed to provide reasonable protection against harmful interference in a residential installation. This equipment generates, uses, and can radiate radio frequency energy and, if not installed and used in accordance with the instructions, may cause harmful interference to radio communications. However, there is no guarantee that interference will not occur in a particular installation. If this equipment does cause harmful interference to radio or television reception, which can be determined by turning the equipment off and on, the user is encouraged to try to correct the interference by one or more of the following measures:

—Reorient or relocate the receiving antenna.

Since the suitability of these products depends upon a wide range of factors not in our control, Rochester Sensors expects and understands that you conduct the testing and evaluation necessary to determine that these products are suitable for your application. While every effort is made to ensure the above details are correct at the time of printing, Rochester Sensors reserves the right to make material changes, and or technical changes without notification.

- Increase the separation between the equipment and receiver.
- Connect the equipment into an outlet on a circuit different from that to which the receiver is connected.
- Consult the dealer or an experienced radio/TV technician for help.

ISED Canada compliance statement

This device complies with ISED Canada license-exempt RSS standard(s). Operation is subject to the following two conditions: (1) this device may not cause interference, and (2) this device must accept any interference, including interference that may cause undesired operation of the device.

Le présent appareil est conforme aux CNR d'ISDE Canada applicables aux appareils radio exempts de licence. L'exploitation est autorisée aux deux conditions suivantes : (1) l'appareil ne doit pas produire de brouillage, et (2) l'appareil doit accepter tout brouillage radioélectrique subi, même si le brouillage est susceptible d'en compromettre le fonctionnement.

E. & O.E. ©Rochester Sensors.

Since the suitability of these products depends upon a wide range of factors not in our control, Rochester Sensors expects and understands that you conduct the testing and evaluation necessary to determine that these products are suitable for your application. While every effort is made to ensure the above details are correct at the time of printing, Rochester Sensors reserves the right to make material changes, and or technical changes without notification.

Environmental Ratings

Parameter	Condition	Min	Typical	Max	Unit
Operating Temperature Range	Temperature Range	-40	-	70	°C
Module Accuracy		-	<1%	-	Level
UV withstand	600 hrs, UVA-340 @.76W/m2, 70°C	-			
Vibration	Mil STD-810: 5 Hz, 12.7mm Amplitude, 1G, 45 minutes				

Dimensions

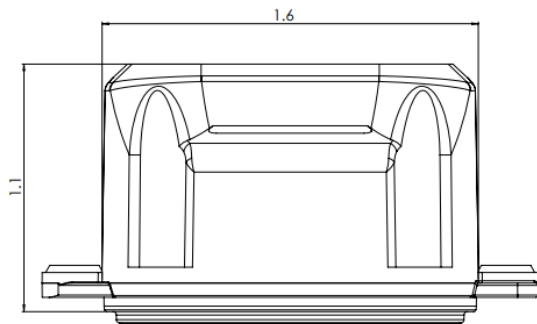

Figure 2: Screw-on Unit

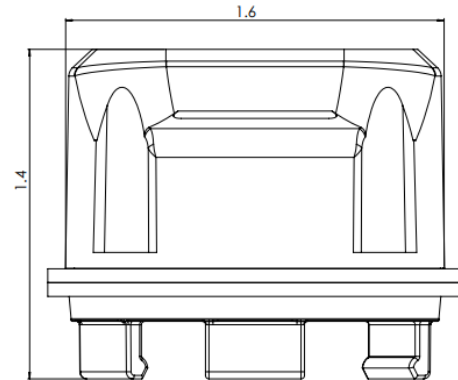

Figure 1: Snap-on unit

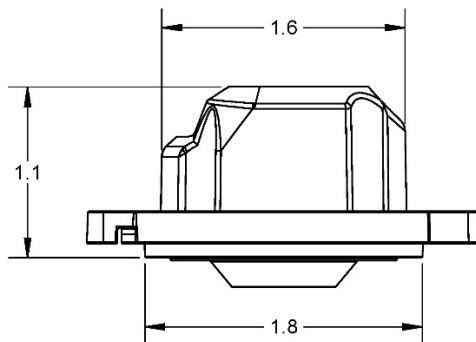

Figure 3: Screw-on Unit with Sr BLE Dial Adapter Ring

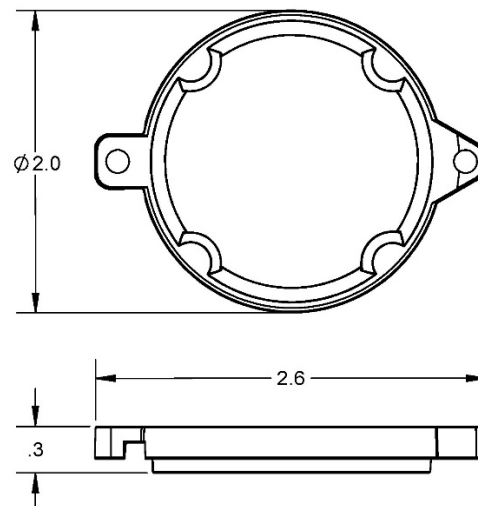

Figure 4: Sr BLE Dial Adapter Ring

E. & O.E. ©Rochester Sensors.

Since the suitability of these products depends upon a wide range of factors not in our control, Rochester Sensors expects and understands that you conduct the testing and evaluation necessary to determine that these products are suitable for your application. While every effort is made to ensure the above details are correct at the time of printing, Rochester Sensors reserves the right to make material changes, and or technical changes without notification.

Part Options: 6318-LT-MMM

L: Warning limits: E for European limits, N for North American Limits

T: H - Horizontal or V Vertical Tanks,

MMM: Mounting Option

Part Number	Model
6318-EH-001	Jr Dial, European Limits, Horizontal Tank, Screw-On
6318-EH-002	Jr Dial, European Limits, Horizontal Tank, Snap-On
6318-EV-001	Jr Dial, European Limits, Vertical Tank, Screw-On
6318-EV-002	Jr Dial, European Limits, Vertical Tank, Snap-On
6318-NH-001	Jr Dial, North American Limits, Horizontal Tank, Screw-On
6318-NH-002	Jr Dial, North American Limits, Horizontal Tank, Snap-On
6318-NV-001	Jr Dial, North American Limits, Vertical Tank, Screw-On
6318-NV-002	Jr Dial, North American Limits, Vertical Tank, Snap-On
6318-EH-003	Sr Dial, European Limits, Horizontal Tank, Screw-On
6318-NH-003	Sr Dial, North American Limits, Horizontal Tank, Screw-On
6318-EV-003	Sr Dial, European Limits, Vertical Tank, Screw-On
6318-NV-003	Sr Dial, North American Limits, Vertical Tank, Screw-On
0021-02914	Sr BLE Dial Adapter Ring

Ordering Information

Contact your local sales representative for samples, availability, and pricing information.







Installation

See Document DS-02041

Disposal

This product contains a battery. At the end of product life, waste batteries should either be recycled or taken to a hazardous waste collection point.

Appendix A

<i>System Conditions</i>	<i>BLE STATUS BYTE</i>	<i>BLE BROADCAST LEVEL</i>	<i>LCD OUTPUT</i>	<i>Description</i>
Normal	0x0	Level	Level	Normal Operation
Device Error	0x1	0xFFFF		Er: Device error. Device is not functioning correctly and electronics should be replaced. The Bluetooth level will be set to 0xFFFF.
Tank Level < 5%	0x2	Level		Measurement Low Low Warning <ul style="list-style-type: none"> LCD displays static "Lo"
Tank Level < 10%**	0x6	Level	Alt Level + "Lo"	Measurement Low Warning <ul style="list-style-type: none"> LCD displays alternating "Lo" and Level
Tank Level > 85%	0x7	Level	Alt Level + "HI"	Measurement High Warning <ul style="list-style-type: none"> LCD displays alternating "HI" and Level
Tank Level > 95%	0x3	Level		Measurement High High Warning <ul style="list-style-type: none"> LCD displays static "HI"
NOT CONNECTED	0x4	0xFFFF		nC: Electronics are not connected to probe. The Bluetooth level will be set to 0xFFFF.
Battery Low	-	Level	 /Level	bL: Battery low. Battery is estimated to be within 1-2 years of expected end of life. The measured level will alternate on the LCD with this code plus any level warning codes (if any)
Battery Critical	-	Level	 /Level	bC: Battery critical. Battery is estimated to be < 1 year of expected end of life. The measured level will alternate on the LCD with this code plus any level warning codes (if any)
Sensor Range	0x1	0xFFFF		Sensor cannot determine a meaningful level from the mechanical gauge. The Bluetooth level will be set to 0xFFFF

** For EU products the LO warning level is 20%