

S288 Oil Level Switch – Capacitance Type



The **S288** is an active device designed to give an alarm signal if liquid falls below, or rises above, a preset level. It can be specified with a delay to eliminate false alarms due to turbulence. A flying lead enables customers to specify a suitable connector of their choice.

Containing a factory programmable microprocessor, the switch offers sink to ground and / or source voltage output. Its small footprint with limited intrusion into the tank means a reduced risk of damage and a wide range of customer specifiable options make it suitable for most applications.

For optimum accuracy, the S288 should be mounted horizontally at the point where an alarm or control signal is required. However, the switch can be mounted vertically – contact Rochester Sensors with your application requirements.



SPECIFICATION

Liquid types:

Mineral oils, typically used in engines or hydraulic actuators, compatible with brass, PTFE and FVMQ.

Electrical rating

Supply voltage: 9-36 VDC.
Supply current: 7 mA + source output.
Max. load current: 1.0 A (sink) or 20 mA (source).
Alarm delay time: 0 to 25 s rising or falling (factory set).
Connection: Flying lead + customer specified connector.
Power up delay: 0 to 10 s (factory set).
Power up state: 'In Liquid' or 'Out of Liquid' (factory set).
Output type: Sink (open collector) and/or Source (supply voltage).
Output state: Sink Open / Closed in liquid (factory set).
 Source On / Off in liquid (factory set).

Construction

Body: Brass - one piece body and probe shroud.
Probe: PTFE.
Terminals: Brass, Tin Plated.
Seals: FVMQ.
Flying lead entry: PA66 30% Glass Filled Nylon.
Flying lead cables: GXL type cable 18 AWG

Connections:

See diagram below.

Environmental Ratings:

Ingress: IP67 (with mating connector fitted).
Max. pressure: 24 Bar (348 psi)
Temp. range: -40 °C to +125 °C
Weight: 70 g typical (dependent on thread size)
EMC: ISO13766:2006

Vibration (15.3 Grms)

3 orthogonal planes for 3 hours per plane
 Testing performed in accordance with BSEN 60068-2-64:1993
Drop: 1 m to concrete surface.

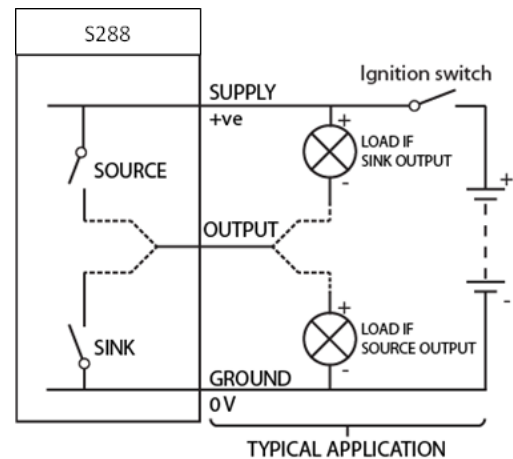
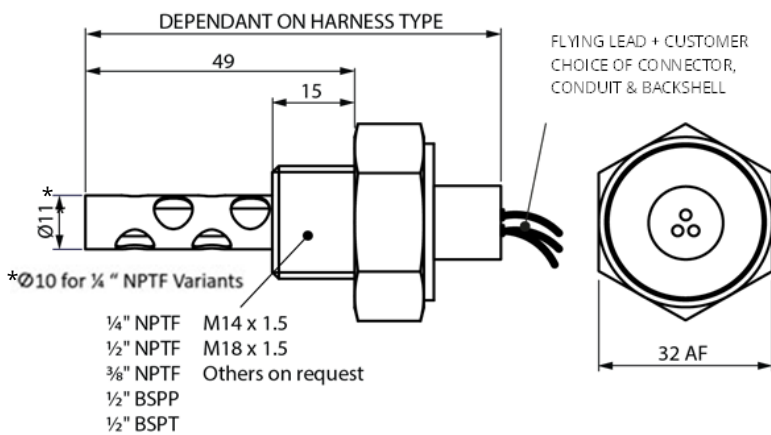

Recommended Installation Tightening Torques:

¼" NPTF	9 Nm	M14x1.5	10 Nm
¾" NPTF	11 Nm	M18x1.5	15 Nm
½" NPTF	20 Nm		
½" BSPP	15 Nm		
½" BSPT	20 Nm		

Optional accessories

This switch can be supplied with any suitable mating plug or receptacle to suit customer applications.