

T/LL400 Extended Temperature Range Liquid Level Sensor



The **T/LL400 Liquid Level Sensor** is an advanced capacitance sensor that continuously monitors liquid level providing a configurable voltage output in the range 0-10 VDC.

Compact and robust this sensor is designed to provide accurate and repeatable liquid level data. It is ideal for extended temperature range applications such as monitoring engine oil or coolant in relatively shallow, sumps or tanks.

SPECIFICATION

Liquid Types

Liquids compatible with the construction materials, typically engine and hydraulic oils, fuels or coolants.

Dimensions

Length: Min. 80 mm, Max. 300mm.
Thread: ½ "BSPT, ½ "BSPP, ½ NPTF, 3/8" NPTF, M14, M18 and M22.

Materials

Header: 316 stainless steel.
Stem: 316 stainless steel.
Internal Electrode: PTFE sheathed stainless steel.
End Plug: PTFE.
Wetted Seals: Fluorosilicone (FVMQ).
Connector Enclosure: 30% glass filled nylon 66 (where fitted).
Leads: XLPE wires sheathed in nylon 6 conduit (where fitted). Back-shell and connector dependant on series.

Electrical

Supply Voltage: 9 to 36 VDC.
Supply Current: 10 mA @ 12 VDC + output load.
Supply Protection: 80 VDC over voltage. Reverse polarity.
Signal Output: Voltage source. 2 kΩ min load. 10 mV resolution.
Range 0 to 5 VDC @ 12 VDC or 24 VDC.
Range 0 to 10 VDC @ 24 VDC.
Output Protection: Short circuit to supply. Short circuit to ground.

Connections:

| | 4P Metri-pack 150 | Deutsch DT04-4P | Flying Lead Top or Side Exit | Description |
|--------|-------------------|-----------------|------------------------------|-------------------------------|
| V+ | C | 2 | Red | +ve supply 9-36 VDC |
| Ground | B | 1 | Black | -ve supply, 0V |
| Output | A | 3 | Green | In range 0-10 VDC |
| Alarm | D | 4 | White | Switch to ground. Max 100 mA. |

Alarm Output: Switch to ground. Max 100 mA. Default low level alarm at 12% of active length. Minimum 23 mm distance from end of probe. Minimum 35 mm from datum.

Environmental Ratings

Ingress: Liquid side - IP68, Connector side - IP67.
Operating Temp: -40°C to 125°C.
Max Tank Pressure: 1 bar.
EMC: Type approval in accordance with EN ISO 13766:2006.
Vibration: 15.3 grms BS EN 60068-2-4:1995.
Shock: 500 ms⁻², 6 ms, BS EN 60068-2-27:1993. **Weight:** 0.16 kg (for 300 mm version).

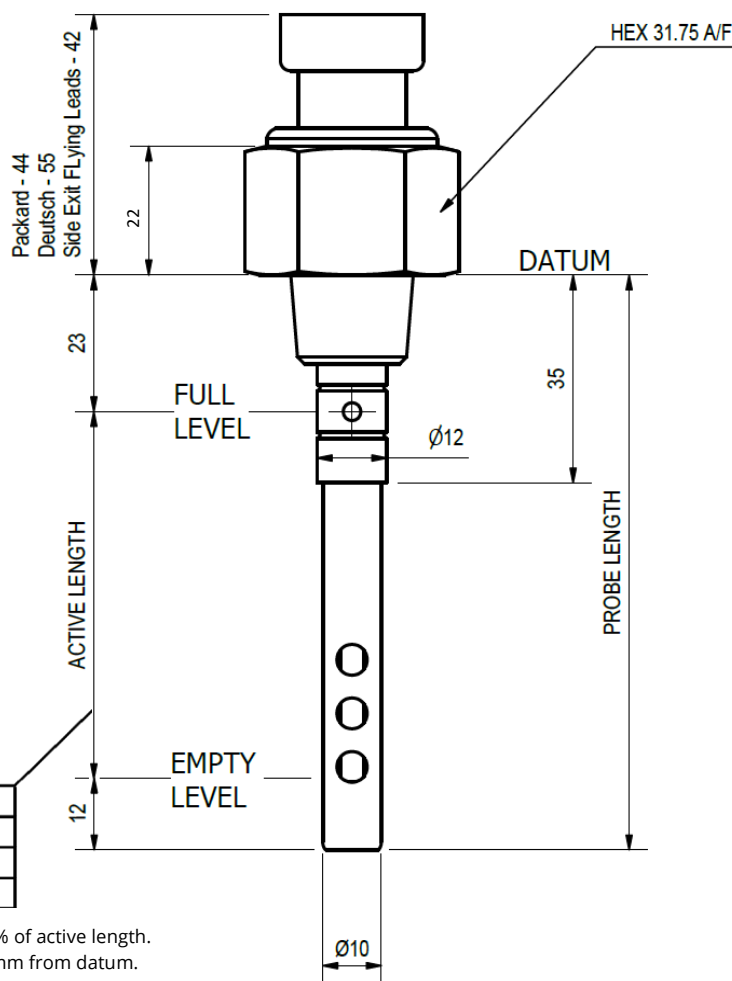

TLL400DATA Rev.3

